



US009283106B2

(12) **United States Patent**
Castillo

(10) **Patent No.:** **US 9,283,106 B2**
(45) **Date of Patent:** **Mar. 15, 2016**

(54) **BREATHING SYSTEM**

(71) Applicant: **James D. Castillo**, Los Alamos, CA (US)

(72) Inventor: **James D. Castillo**, Los Alamos, CA (US)

(*) Notice: Subject to any disclaimer, the term of this patent is extended or adjusted under 35 U.S.C. 154(b) by 0 days.

(21) Appl. No.: **14/622,448**

(22) Filed: **Feb. 13, 2015**

(65) **Prior Publication Data**

US 2015/0173934 A1 Jun. 25, 2015

Related U.S. Application Data

(63) Continuation-in-part of application No. 14/502,348, filed on Sep. 30, 2014.

(60) Provisional application No. 61/918,826, filed on Dec. 20, 2013, provisional application No. 61/937,018, filed on Feb. 7, 2014.

(51) **Int. Cl.**
A61F 5/08 (2006.01)

(52) **U.S. Cl.**
CPC **A61F 5/08** (2013.01)

(58) **Field of Classification Search**
CPC A61F 5/08
USPC 606/199, 204.45, 232; 128/207.18, 846, 128/859; 604/514
See application file for complete search history.

(56) **References Cited**

U.S. PATENT DOCUMENTS

3,835,848 A 9/1974 Berner

5,533,503 A	7/1996	Doubek et al.
5,913,873 A	6/1999	Blach et al.
6,006,746 A	12/1999	Karell
6,033,422 A	3/2000	Blach et al.
6,352,548 B1	3/2002	Blach et al.
6,533,412 B1	3/2003	Wang et al.
6,676,681 B1	1/2004	Blach et al.
6,823,864 B2	11/2004	Blach et al.
7,091,634 B2	8/2006	Yi et al.
D639,762 S	6/2011	Brogden et al.
D644,324 S	8/2011	Brunner et al.
D644,325 S	8/2011	Brunner et al.
8,042,542 B2	10/2011	Ging et al.
D696,400 S	12/2013	Brogden et al.
D701,957 S	4/2014	Brunner et al.
D703,318 S	4/2014	Brunner et al.
2007/0105824 A1	5/2007	Erickson-Miller et al.
2008/0097517 A1	4/2008	Holmes et al.
2009/0188023 A1	7/2009	Hsu
2011/0000483 A1	1/2011	Matthias et al.
2012/0036607 A1	2/2012	Beliveau
2012/0172923 A1	7/2012	Fenton et al.

OTHER PUBLICATIONS

International Search Report and Written Opinion for International Application No. PCT/US14/69817, Mar. 11, 2015, 11 pages.

Primary Examiner — Vy Bui

(74) *Attorney, Agent, or Firm* — Stetina Brunda Garred & Brucker

(57) **ABSTRACT**

A breathing system is provided which enhances the ability of a user to breathe through the user's nasal passageways. The breathing system generally includes a bridge member and a pair of nasal appliques which are attachable to the lateral portions of the user's nose. The bridge member is positionable adjacent the appliques to activate the system and impart a dilating force onto the user's nose. The system may be deactivated by removing the bridge member from the appliques, and thereby removing the dilating force from the user's nose.

28 Claims, 7 Drawing Sheets

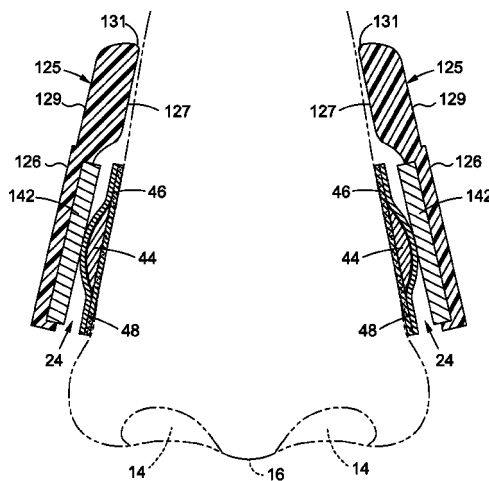

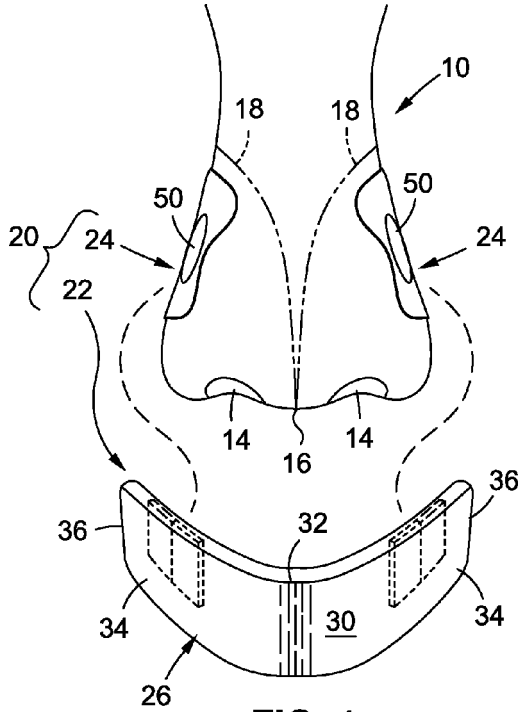

FIG. 1

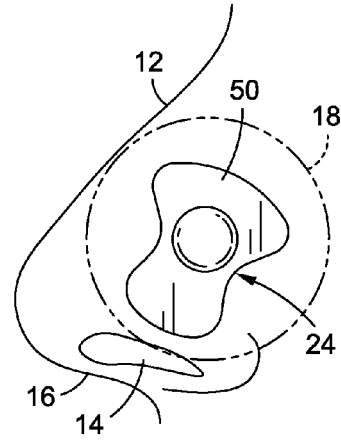

FIG. 2

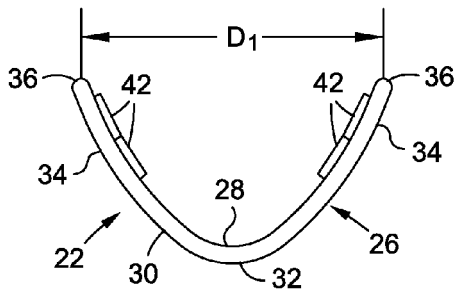

FIG. 3

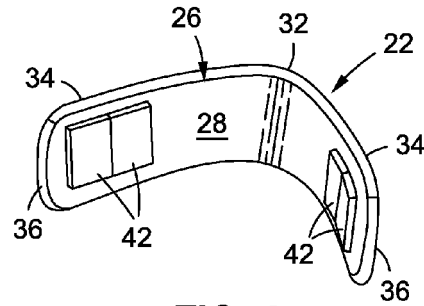

FIG. 4

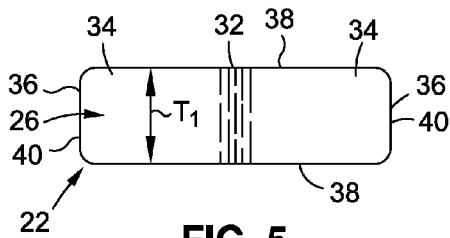

FIG. 5

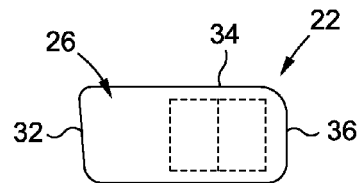

FIG. 6

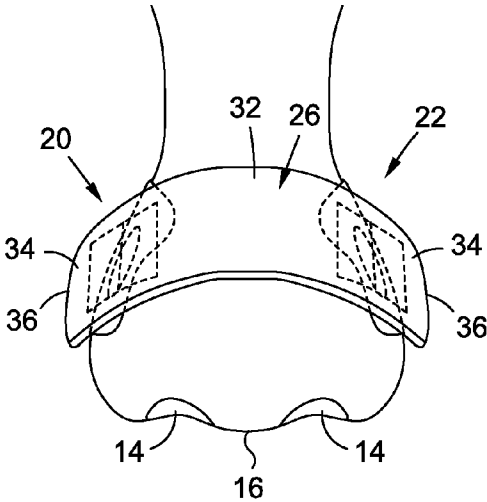

FIG. 7

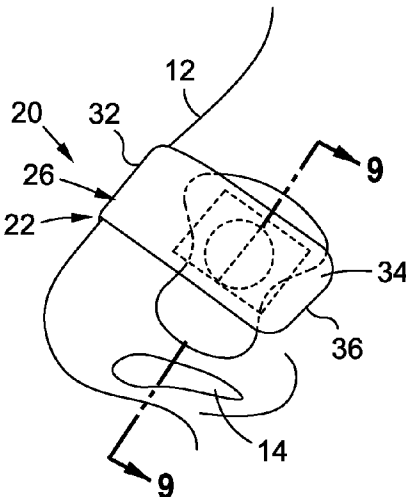

FIG. 8

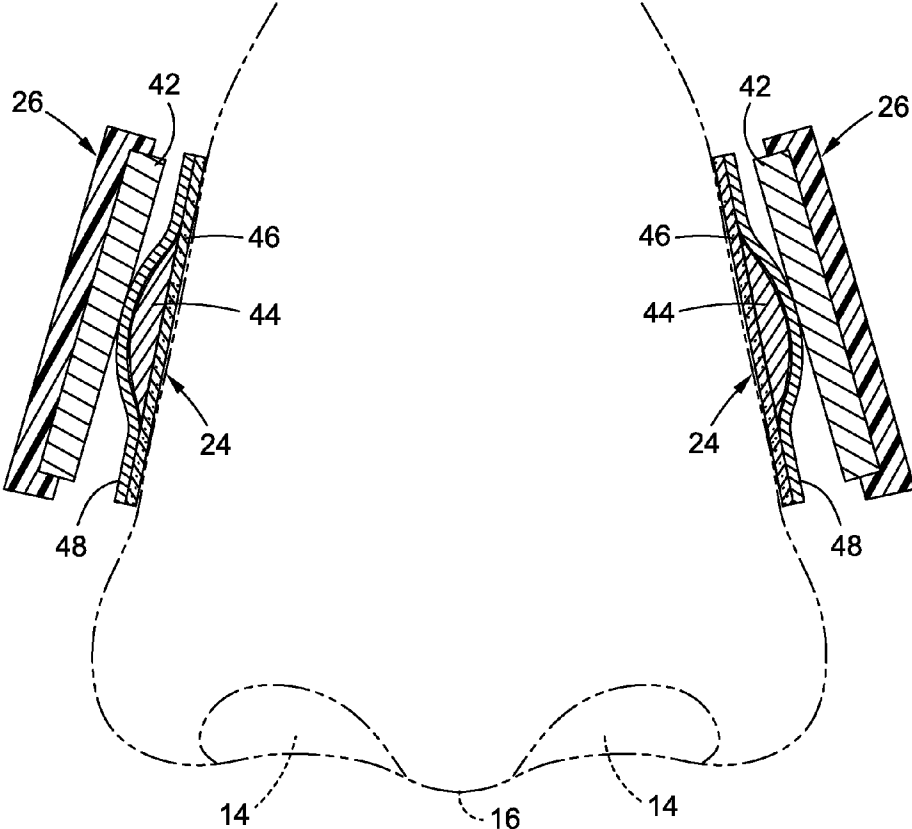
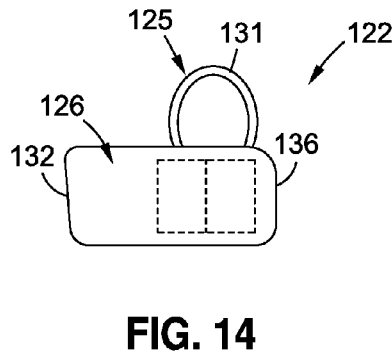
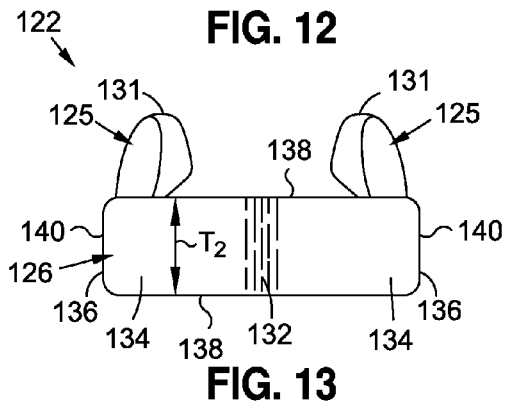
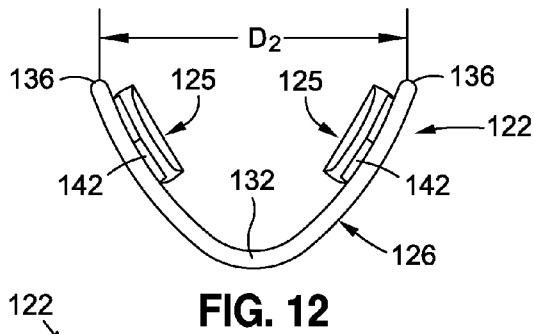
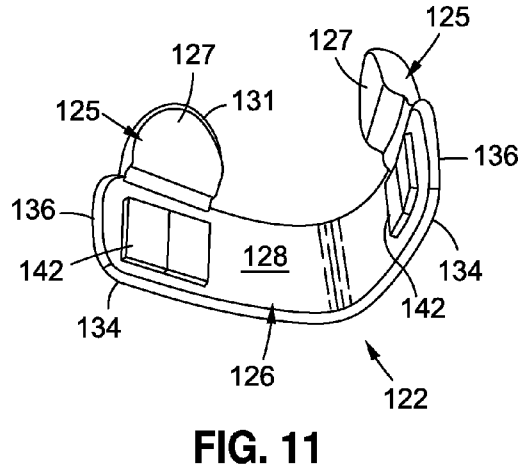
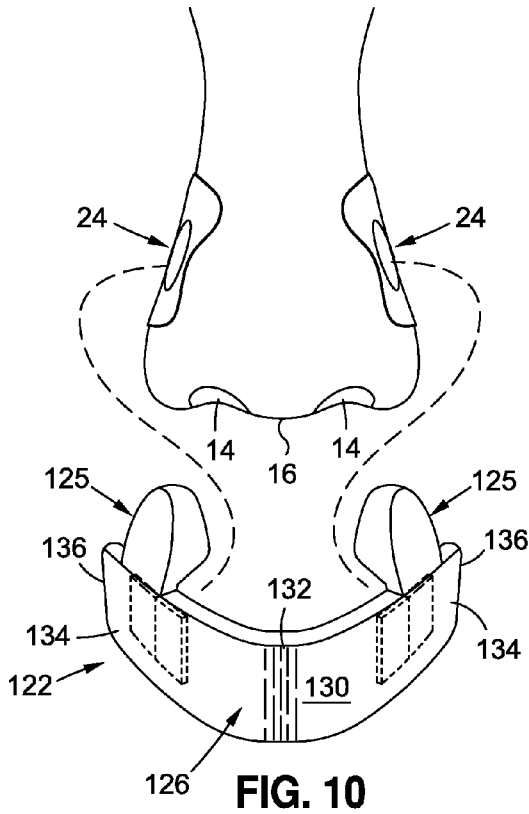

FIG. 9



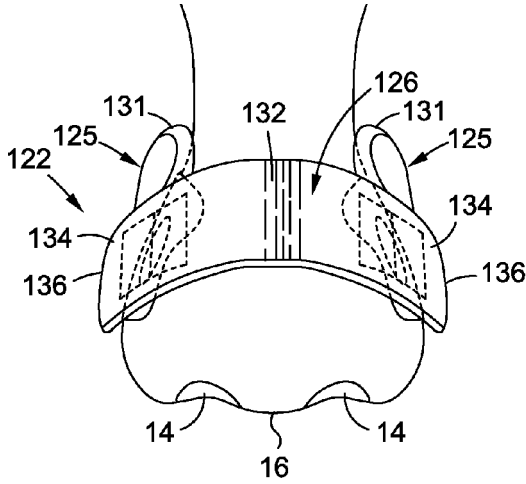

FIG. 15

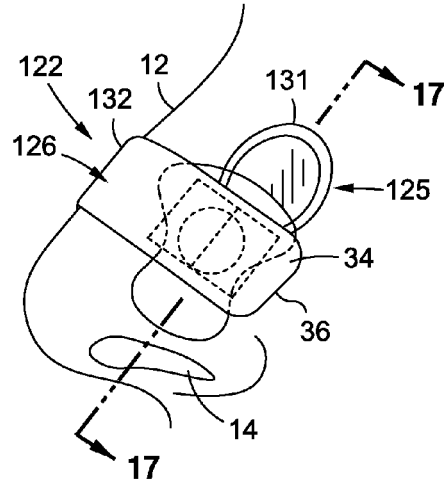

FIG. 16

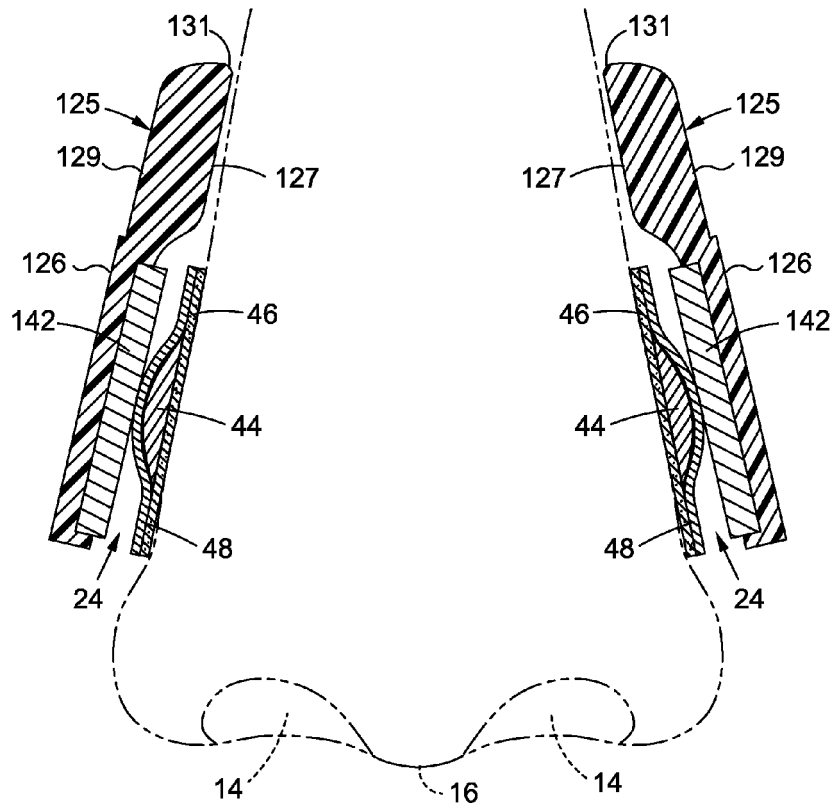

FIG. 17

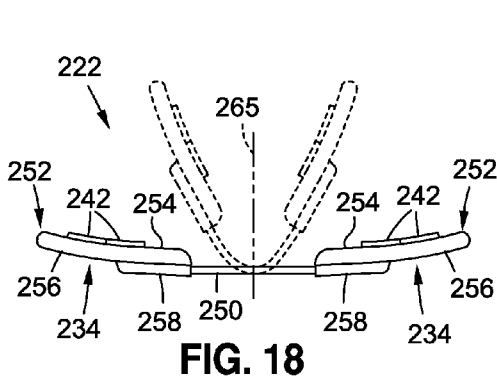

FIG. 18

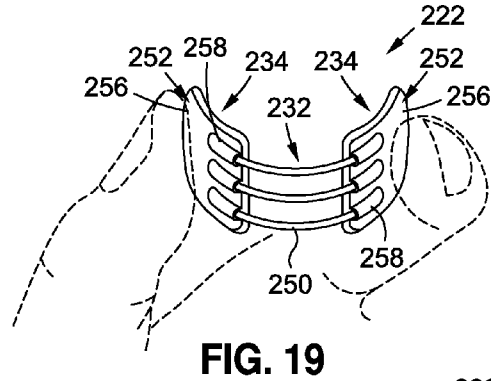

FIG. 19

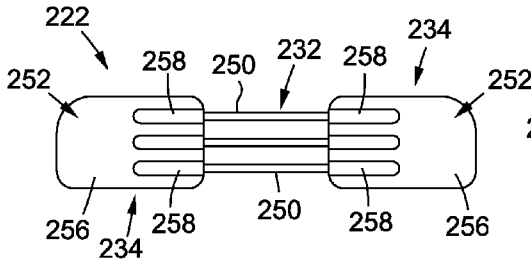

FIG. 20

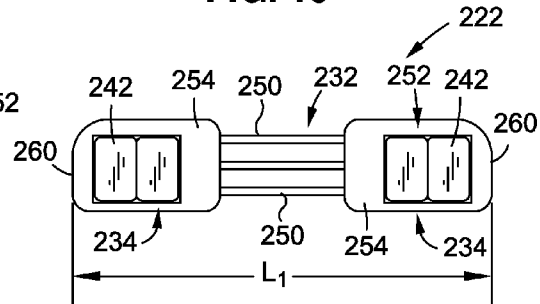

FIG. 21

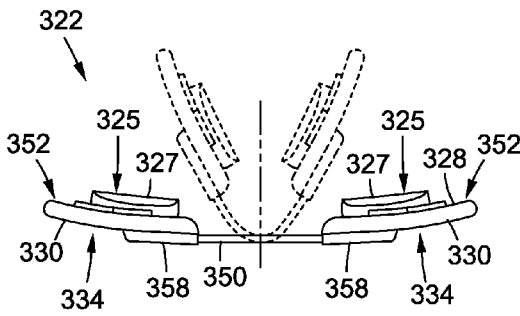

FIG. 22

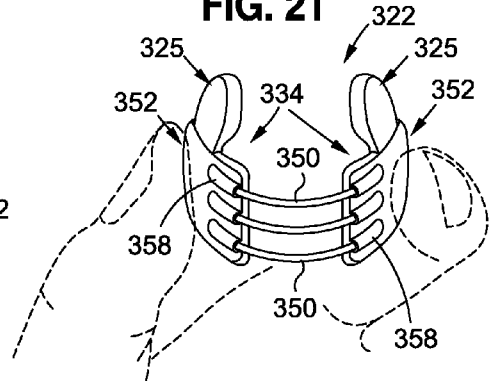

FIG. 23

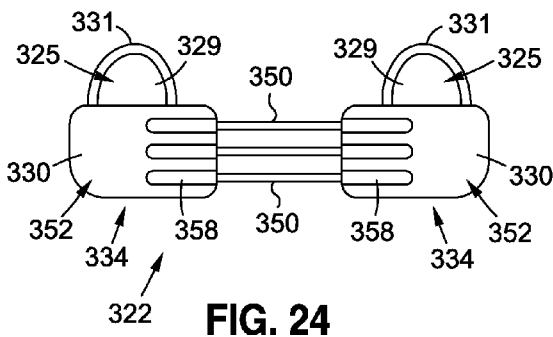

FIG. 24

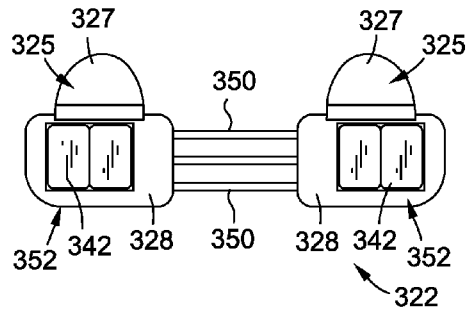

FIG. 25

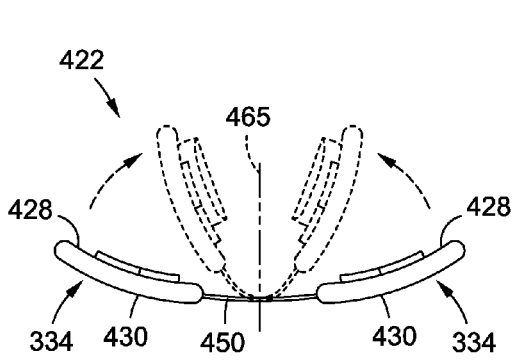

FIG. 26

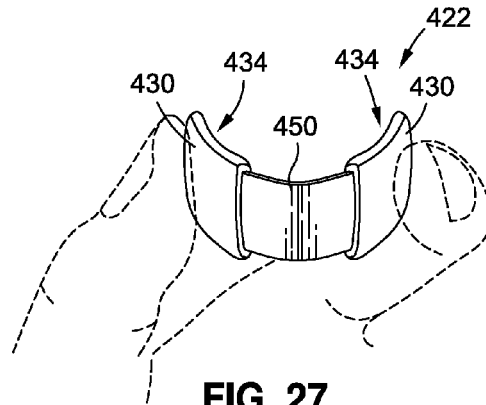

FIG. 27

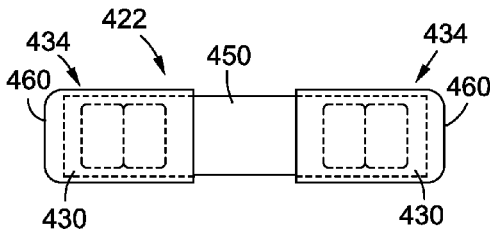

FIG. 28

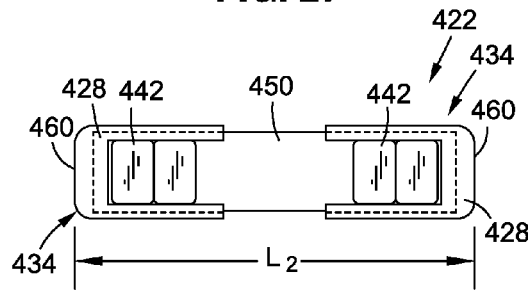

FIG. 29

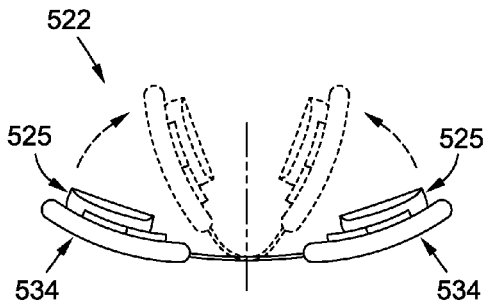

FIG. 30

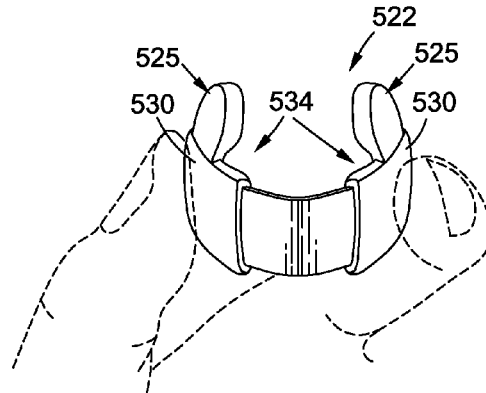

FIG. 31

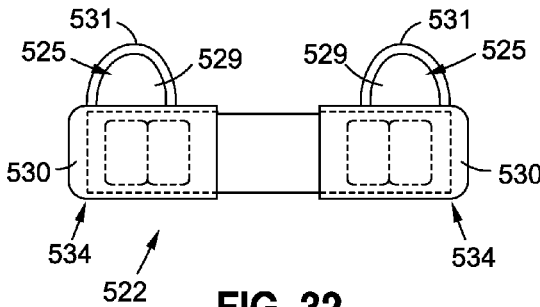

FIG. 32

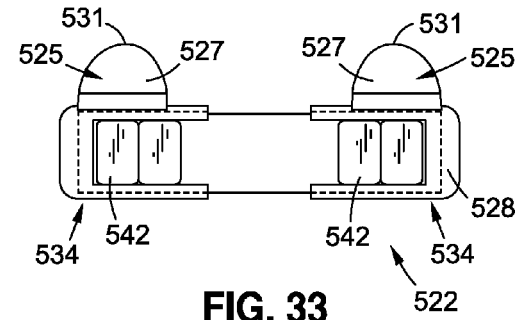

FIG. 33

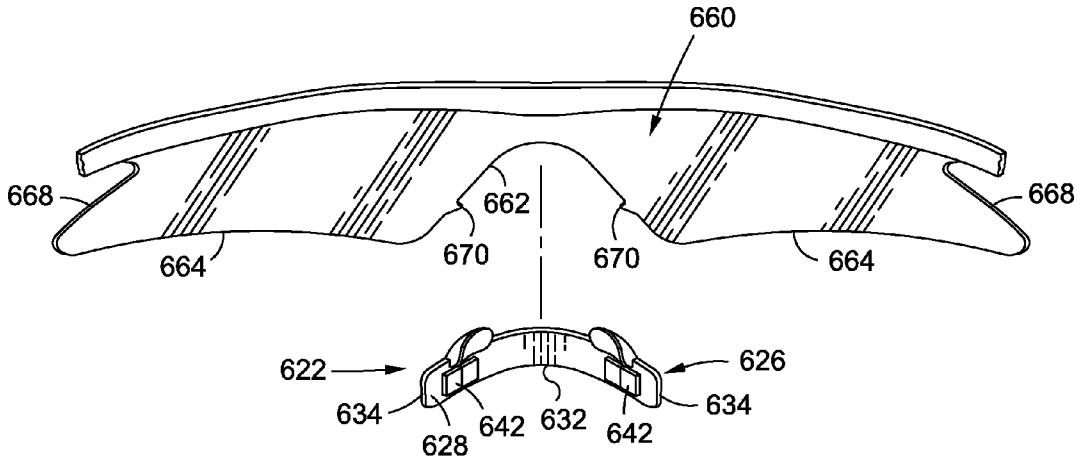

FIG. 34

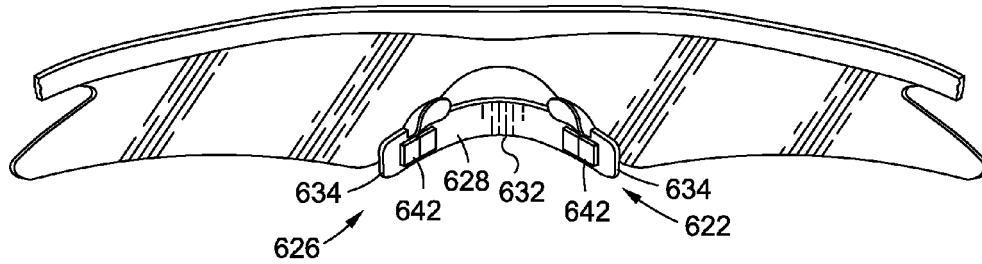

FIG. 35

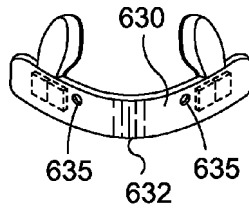

FIG. 36

1

BREATHING SYSTEMCROSS-REFERENCE TO RELATED
APPLICATIONS

This application is a continuation-in-part of U.S. patent application Ser. No. 14/502,348, filed Sep. 30, 2014, which claims the benefit of U.S. Provisional Application No. 61/918,826, filed Dec. 20, 2013, and U.S. Provisional Application No. 61/937,018, filed Feb. 7, 2014, the contents of each of the foregoing applications being expressly incorporated herein by reference.

STATEMENT RE: FEDERALLY SPONSORED
RESEARCH/DEVELOPMENT

Not Applicable

BACKGROUND OF THE INVENTION

1. Field of the Invention

The present invention relates generally to a breathing system, and more specifically to a breathing system designed to enhance nasal airflow for the user by urging the user's nostrils to a more open position, wherein the breathing system may optionally be used with an optical lens as a stabilizing mechanism for the lens.

2. Description of the Related Art

It is readily understood that breathing is important when playing sports or taking part in physical competition due to the increased demand for oxygen by the body. Breathing may be achieved by drawing air into the body through an individual's nostrils and/or through the individual's mouth. However, in some instances, it is preferable to breathe almost exclusively through the nostrils, as there may be a downside to breathing through one's mouth. Along these lines, breathing through the mouth may lead to rapid water loss and heat loss, both of which increase the likelihood of exercise-induced asthma. Exclusive breathing through the mouth may also lead to an increased heart rate, hyperventilation and reduced athletic ability.

It is also understood that eyewear is commonly used when participating in many sports and activities. Such eyewear may include protective eyewear, or vision-enhancing (e.g., prescription) eyewear. For instance, goggles are readily worn by many athletes participating in snowboarding, skiing, motocross, automotive racing, basketball, baseball, hockey, etc. Goggles are typically configured such that a portion of the goggle frame extends over the user's nose, and thus, goggles may impact one's ability to breathe through the user's nasal passage.

Moreover, many goggles are fitted with a foam liner which interfaces with the user's face to create a barrier or seal which prevents snow, rain, dirt or other debris from entering the goggles and creating a potential irritant in the user's eye. In order to create an effective seal or barrier around the goggles, the goggles are compressed against the user's face, typically through the use of an elastic band which is worn around the head. The compression of the foam liner against the user tends to compress the nasal passages of the user, which further inhibits the ability of the user to breathe through the nose.

In view of the foregoing drawbacks associated with conventional goggles, Applicant has developed a goggle breathing system directed toward alleviating the pressure on the nostrils and improving the user's ability to breathe when wearing goggles. More information regarding Applicant's

2

goggle breathing system can be found in U.S. patent application Ser. No. 14/502,348, entitled Goggle Breathing System.

However, in some instances, eyewear or goggles are not worn by the user. For instance, sports such as basketball, baseball, soccer, running, volleyball, hockey, and skateboarding typically do not require the use of goggles or other eyewear. However, there remains a need for enhancing one's ability to breathe.

Accordingly, there is a need in the art for a device specifically adapted for enhancing the user's ability to breathe through the user's nasal passage. Various aspects of the present invention address this particular need, as will be discussed in more detail below.

BRIEF SUMMARY OF THE INVENTION

In accordance with one embodiment of the present invention, there is provided a breathing system which enhances the ability of a user to breathe through the user's nasal passageways. Various embodiments of the breathing system do not require the use of goggles or other eyewear. Rather, the breathing system generally includes a bridge member and a pair of nasal appliques which are attachable to the lateral portions of the user's nose. The bridge member is positionable adjacent the appliques to activate the system and impart a dilating force onto the user's nose. The system may be deactivated by removing the bridge member from the appliques, and thereby removing the dilating force from the user's nose. The dilating force may be selectively turned ON and OFF. The dilating effect may be most noticeable when the bridge member is first applied. This may allow the user to have the advantage only when engaged in the activity for which the user is using the breathing system.

According to one embodiment, the breathing system includes a bridge member having a pair of distal portions and a middle portion positioned between the pair of distal portions. The bridge member is configured to be positionable adjacent the user's nose, with each distal portion residing adjacent a respective lateral region of the user's nose. A pair of nasal appliques are adapted to be attachable to the respective lateral regions of the user's nose, with each nasal applique being magnetically attractable to respective ones of the pair of distal portions. The attraction between the pair of nasal appliques and the bridge member impart a dilating force on the user's nose to dilating the nasal passage.

Each nasal applique may include a flexible base layer including a first surface and an opposing second surface. The first surface may include an adhesive disposed thereon to enable the first surface to be selectively attachable to the nose of the user. A metallic element may be coupled to the second surface of the base layer. The bridge member may include a main body and a pair of magnets coupled to the main body at respective ones of the distal portions of the bridge member. The metallic element in each nasal applique may be magnetically attractable to a respective one of the pair of magnets.

The bridge member may include a first surface and an opposing second surface, the first surface facing toward the user's nose and the second surface facing away from the user's nose when the bridge member is positioned adjacent the user's nose. A pair of spacers may extend from the first surface and away from the second surface, with each spacer being positioned at a respective one of the pair of distal portions. The spacers may be integrally formed with the main body.

The bridge member may be substantially inflexible.

The bridge member may be configured to be selectively flexible between a neutral position and a flexed position. The

bridge member may be configured to substantially remain in the flexed position once transitioned thereto. The bridge member may include at least one flexible member and a pair of distal members coupled to opposed ends of the at least one flexible member. The at least one flexible member may be selectively bendable to place the bridge member in a prescribed orientation. The bridge member may be biased toward the neutral position.

The bridge member may include a flexible band and a pair of distal members coupled to opposed ends of the flexible band. The flexible band may be bendable between neutral and flexed positions, with the band being biased toward the neutral position.

The bridge member may be adapted to be attachable to eyewear, such as a lens. The bridge member may be configured to stabilize or support the lens on the face of the user.

According to another embodiment, there is provided a breathing system including a pair of nasal appliques configured to be attachable to an outer surface of a user's nose adjacent a user's nostrils. A bridge member is configured to be selectively positionable adjacent the nose of the user and to interact with the pair of nasal appliques. The pair of nasal appliques and the bridge member are configured to selectively transition between an ON state wherein the pair of nasal appliques interact with the bridge member to apply a dilating force on the nose of the user, and an OFF state wherein the bridge member is moved away from the pair of nasal appliques to cease application of the dilating force on the nose of the user.

The present invention will be best understood by reference to the following detailed description when read in conjunction with the accompanying drawings.

BRIEF DESCRIPTION OF THE DRAWINGS

These and other features and advantages of the various embodiments disclosed herein will be better understood with respect to the following description and drawings, in which:

FIG. 1 is an upper perspective view of a breathing system constructed in accordance with a first embodiment of the present invention, the breathing system including a pair of nasal appliques and a bridge member which interacts with the nasal appliques;

FIG. 2 is a side view of a nasal applique applied to a lateral region of a user's nose;

FIG. 3 is a top view of the bridge member depicted in FIG. 1;

FIG. 4 is a rear perspective view of the bridge member depicted in FIG. 1;

FIG. 5 is a front view of the bridge member depicted in FIG. 1;

FIG. 6 is a side view of the bridge member depicted in FIG. 1;

FIG. 7 is an upper perspective view of the bridge member engaged with the pair of nasal appliques (depicted in dashed lines);

FIG. 8 is a side view of the bridge member and the pair of nasal appliques (depicted in dashed lines) illustrated in FIG. 7;

FIG. 9 is a cross sectional view of the bridge member and the pair of nasal appliques taken along line 9-9 depicted in FIG. 8;

FIG. 10 is an upper perspective view of a second embodiment of a breathing system including a bridge member having a pair of spacers, and a pair of nasal appliques;

FIG. 11 is a rear perspective view of the bridge member depicted in FIG. 10;

FIG. 12 is a top view of the bridge member depicted in FIG. 10;

FIG. 13 is a front view of the bridge member depicted in FIG. 10;

FIG. 14 is a side view of the bridge member depicted in FIG. 10;

FIG. 15 is an upper perspective view of the bridge member depicted in FIG. 10 engaged with the pair of nasal appliques (depicted in dashed lines);

FIG. 16 is a side view of the bridge member and the nasal applique (depicted in dashed lines) illustrated in FIG. 15;

FIG. 17 is a cross sectional view of the bridge member and the pair of nasal appliques taken along line 17-17 depicted in FIG. 16;

FIG. 18 is a top view of a third embodiment of a bridge member, the bridge member being transitional between a neutral position and a flexed position (depicted in dashed lines);

FIG. 19 is an upper perspective view of the bridge member depicted in FIG. 18, the bridge member being shown in a flexed position;

FIG. 20 is a front view of the bridge member depicted in FIG. 18;

FIG. 21 is a rear view of the bridge member depicted in FIG. 18;

FIG. 22 is a top view of a fourth embodiment of a bridge member being transitional between a neutral position and a flexed position (depicted in dashed lines), wherein the bridge member includes a pair of spaces coupled thereto;

FIG. 23 is an upper perspective view of the bridge member depicted in FIG. 22, the bridge member being shown in a flexed position;

FIG. 24 is a front view of the bridge member depicted in FIG. 22;

FIG. 25 is a rear view of the bridge member depicted in FIG. 22;

FIG. 26 is a top view of a fifth embodiment of a bridge member being transitional between a neutral position and a flexed position (shown in dashed lines);

FIG. 27 is an upper perspective view of the bridge member depicted in FIG. 26, the bridge member being shown in a flexed position;

FIG. 28 is a front view of the bridge member depicted in FIG. 26;

FIG. 29 is a rear view of the bridge member depicted in FIG. 26;

FIG. 30 is a top view of a sixth embodiment of a bridge member being transitional between a neutral position and a flexed position (shown in dashed lines);

FIG. 31 is an upper perspective view of the bridge member depicted in FIG. 30, the bridge member being shown in a flexed position;

FIG. 32 is a front view of the bridge member depicted in FIG. 30;

FIG. 33 is a rear view of the bridge member depicted in FIG. 30;

FIG. 34 is a rear view of a seventh embodiment of a bridge member adapted to interface with eyewear, the bridge member being disengaged from the eyewear;

FIG. 35 is a rear view of the bridge member depicted in FIG. 34, the bridge member being engaged with the eyewear; and

FIG. 36 is a front upper perspective view of the bridge member depicted in FIGS. 34 and 35.

Common reference numerals are used throughout the drawings and the detailed description to indicate the same elements.

DETAILED DESCRIPTION OF THE INVENTION

The detailed description set forth below in connection with the appended drawings is intended as a description of certain embodiments of a breathing system and is not intended to represent the only forms that may be developed or utilized. The description sets forth the various structure and/or functions in connection with the illustrated embodiments, but it is to be understood, however, that the same or equivalent structure and/or functions may be accomplished by different embodiments that are also intended to be encompassed within the scope of the present disclosure. It is further understood that the use of relational terms such as first and second, and the like are used solely to distinguish one entity from another without necessarily requiring or implying any actual such relationship or order between such entities.

Referring now to the drawings, wherein the showings are for purposes of illustrating preferred embodiments of the present invention only, and are not for purposes of limiting the same, there is depicted several embodiments of breathing system for enhancing the ability of a user to breathe through the user's nose by opening the user's nasal passageways. As will be described in more detail below, the embodiments depicted in FIGS. 1-33 are specifically configured and adapted to interface with the user's nose without relying upon eyewear, such as glasses, goggles, or the like, to support the breathing system on the user's nose. However, in the event the user does wear a lens, such as a prescription lens, uv-protective lens, or other lens, other embodiments are specifically configured and adapted to interface with such a lens, specifically the embodiment depicted in FIGS. 34 and 35.

Various aspects of the present invention are directed toward imparting a dilating force on the user's nose to open the user's nasal passageways. Along these lines, the anatomy of the human nose 10 generally includes a nasal ridge 12, a pair of nasal passageways 14, which are separate by a nasal septum 16. The nose 10 also includes skin extending over the lateral regions 18 (see FIGS. 1 and 2) thereof, which may be referred to as the "ala of the nose." The dilating force is applied on the lateral regions 18 of the nose 10 to cause the lateral regions 18 to flare outwardly, thereby increasing the volume of the nasal passageways 14.

Referring now specifically to FIGS. 1-9, there is depicted a first embodiment of a breathing system 20 which generally includes a bridge member 22 and a pair of nasal appliques 24. The bridge member 22 includes an arcuate main body 26 having a concave inner surface 28 and an opposing convex outer surface 30. The main body 26 includes a middle portion 32 defining an apex which is located between two distal portions 34, wherein each distal portion terminates 34 at a respective distal tip 36. The two distal tips 36 are spaced from each other by a distance, D_1 which allows the bridge member 22 to fit over the user's nose 10, with the distal portions 34 being positioned adjacent opposing lateral regions 18 of the user's nose 10. The bridge member 22 may be fabricated in various sizes to accommodate differently sized noses. Along these lines, the distance D_1 may be anywhere from 1.0 inch for use on a small nose (e.g., for a child), to over 2.5 for use on a larger nose. For an average nose, the distance D_1 may be approximately equal to 1.75 inches.

The main body 26 includes a pair of opposed longitudinal edges 38 (see FIG. 5) and a pair of opposed transverse edges 40, which essentially define the aforementioned distal tips 36. The distance between the opposed longitudinal edges 38 defines a bridge member thickness, T_1 , which may be equal to

approximately 0.5 inches, although other thickness dimensions may be used without departing from the spirit and scope of the present invention.

The main body 26 is rigidly formed so as to substantially maintain its shape. Along these lines, the main body 26 is preferably more resistant to bending, or flexing than is the skin of the user's nose 10. In this respect, the main body 26 is capable of being disposable in compression, that is to say, the main body 26 is capable of having a force applied thereto.

The bridge member 22 further includes a plurality of magnets 42 coupled to the concave inner surface 28 adjacent the distal portions 34 of the main body 26. In the exemplary embodiment, the bridge member 22 includes a pair of magnets 42 at each distal portion 34. The magnets 42 may be received within a cavity or recess formed within the main body 26 that is substantially complimentary in shape and size to the pair of magnets 42. The magnets 42 may be adhered or otherwise coupled to the main body 26 using fastening mechanisms known by those skilled in the art.

The nasal applique 24 includes a metallic element 44, preferably a ferrous metal, that is captured between a base layer 46 and a cover layer 48. It is understood that the cover layer 48 is optional, as there may be other embodiments wherein the metallic element 44 is coupled to the base layer 46, with the metallic element 44 being uncovered. The metallic element 44 includes a first surface which interfaces with the base layer 46 and a second surface which interfaces with the cover layer 48. According to one embodiment, the second surface defines a convex, arcuate, or "domed" configuration, to facilitate contact with the magnets 42 without flat-to-flat attachment, which may create uncomfortable torque on the user's nose 10. As alluded to above, it is understood that the dual-layer design is optional, and that in other embodiments, the nasal applique 24 may comprise a single layer with the metallic element 44 coupled to the single layer. In this regard, the metallic element 44 may be position on an upper surface of the single layer, wherein the single layer resides between the metallic element 44 and the user when the applique 24 is applied to the user's nose. Alternatively, the metallic element 44 may be positioned on a lower surface of the single layer, such that the metallic element 44 resides between a portion of the single layer and the user's nose during use. It is also contemplated that the metallic element 44 may be encapsulated or captured within that single layer.

The base layer 46 includes an inner surface and an opposing outer surface. The inner surface is adapted to engage with the metallic element 44 and the cover layer 48, while the outer (lower) surface is adapted to engage with the user's nose 10. The outer (lower) surface may be coated with an adhesive to allow the base layer 46 to be adhered to the user's nose 10. A tear-away layer (not shown) may extend over the outer surface to preserve the adhesive until the nasal applique 24 is applied to the user's nose 10. The cover layer 48 also includes an inner surface and an opposing exposed surface. The inner surface of the cover layer 48 is adapted to interface with the metallic element 44 and the base layer 46, while the exposed surface of the cover layer 48 is adapted to engage with the magnets 42 of the bridge member 22.

The preferred peripheral contour of the nasal applique 24 is an hour-glass like configuration, having two enlarged end portions and a narrow middle portion, with the metallic element 44 being located at the narrow middle portion. The narrow middle portion is defined by a pair of opposed cutouts. When the nasal applique 24 is applied to the nose, the cutouts are placed over the crease on the user's nose that extends generally around a flared nostril. This provides a cutout around the crease, which becomes very active when breath-

ing. Having that portion of the nose uncovered allows for dilating and breathing motion without initiating peeling of the applique 24. The opposed cutouts allow for use of the applique 24 on either side of the user's nose. However, it is also contemplated that the applique 24 may be specifically formed for use on only one side of the nose, and thus, such appliques 24 may only have one cutout.

It is contemplated that the nasal appliques 24 may have logos, trademarks, or other indicia emblazoned thereon. The indicia may be emblazoned on the base layer 46 and/or the cover layer 48.

According to one embodiment, the base layer 46 and cover layer 48 are both configured to extend radially outward beyond the outer periphery of the metallic element 44 to define a peripheral ring portion 50. As such, the metallic element 44 is positioned over a central region of the base layer 46 and is surrounded by a peripheral region of the base layer 46. In the exemplary embodiment, depicted in FIG. 9, the outer peripheries of the cover layer 48 and the base layer 46 are substantially equal. However, it is understood that prior to being joined to the metallic element 44 and base layer 46, the cover layer 48 may define a peripheral dimension that is larger than the base layer 46 so as to accommodate the thickness of the metallic element 44.

In order to use the breathing system 20, the user first applies the nasal appliques 24 to both sides of the user's nose 10. If the outer surface of the base layer 46 is covered by a tear-away layer, the user removes the tear-away layer to expose the adhesive. The user then places a first nasal applique 24 on a first lateral region 18 (e.g., the ala of the nose) adjacent a first nostril opening 14, and a second nasal applique 24 on a second lateral region 18 adjacent a second nostril opening 14. Typically, the appliques 24 are placed on the nose near the transition of the nose bone.

Once both nasal appliques 24 are applied to the respective lateral regions 18 of the nose 10, the user may place the bridge member 22 over the nose 10, with the magnets 42 on the bridge member 22 being placed adjacent respective ones of the nasal appliques 24 to allow the metallic elements 44 in the nasal appliques 24 to be magnetically drawn to the magnets 42 in the bridge member 22. The interaction between the metallic elements 44 and the magnets 42 creates dilating forces which are imparted to the respective lateral regions 18 of the nose 10 via the interconnection of the nasal appliques 24 to the nose 10. The dilating forces urge the lateral regions 18 of the nose 10 outward, which increases the size of the nasal passageways 14 to enhance the user's ability to breathe. The bridge member 22 substantially retains its shape as it is placed over the user's nose 10, despite the increased magnetic attraction between the magnets 42 and the metallic elements 44. Along these lines, the bridge member's resistance to bending or flexing causes the lateral regions 18 of the nose to be drawn to the bridge member 22, rather than the bridge member 22 being drawn to the nose 10.

Furthermore, the central positioning of the metallic element 44 relative to the underlying base layer 46 causes the central portion of the base layer 46 to be pulled toward the magnet 42 when the magnet 42 is placed adjacent the metallic element 44. The centrally applied force on the base layer 46 creates a shear force between the base layer 46 and the user's nose 10. In this respect, although the magnetic attraction between the magnet 42 and the metallic element 44 pulls the metallic element 44 along an axis extending between the magnet 42 and the metallic element 44, the generally central location of the metallic element 44 within the applique 24 distributes a portion of the force created by the attraction of the metallic element 44 in the applique 24 and the positioned

magnets 42 to the compliant area around the metallic element 44 which substantially translates the force to shear in a plane along the skin of the user's nose, which is generally offset from the axis extending between the magnet 42 and the metallic element 44, and in some instances, may be perpendicular to such axis. The shear component allows for a much more aggressive dilation compared to systems that pull generally perpendicularly to the skin, as the adhesives are much stronger in shear.

The bridge member 22 remains on the user's nose 10 as long as the user desires. Along these lines, the bridge member 22 is specifically configured and adapted to allow the user to compete in a sporting event or other activities with the bridge member 22 coupled to the user's nose 10. In this respect, the attraction between the magnets 42 and the metallic elements 44 is strong enough to maintain the bridge member 22 in place while the user participates in such events or activities under normal circumstances and impact.

One particular advantage of the breathing system 20 is the ability of the system 20 to selectively transition between an ON (engaged) state and an OFF (disengaged) state without removing the nasal appliques 24 from the user's nose 10. In the ON state, the nasal appliques 24 are applied to the user's nose 10, and the bridge member 22 is engaged with the nasal appliques 24, which results in the dilating force being imparted on the user's nose 10. The breathing system 20 may transition from the ON state to the OFF state by disengaging the bridge member 22 from the nasal appliques 24, which stops the application of the dilating force on the user's nose 10. In this regard, when the system 20 is in the OFF state, the system 20 is inactive. If the user subsequently wants to turn the system 20 back ON, the user simply re-applies the bridge member 22 over the nose 10 and into engagement with the nasal appliques 24.

The ability to selectively transition the system 20 between ON and OFF states may be particularly advantageous, particularly when participating in sports-related activities, where the user may take breaks from time-to-time. For instance, many sports relates activities are divided into heats, periods, quarters, halves, etc., such that the user experiences extended periods of inactivity between extended active periods. The user may want to transition the system 20 to the OFF state during periods of inactivity, and to the ON state during periods of activity. The configuration of the nasal appliques 24 and the associated bridge member 22 allows for such quick and easy transition to give the user the enhanced ability to breathe when needed during the active periods. The selective transition of the system 20 between an ON state and an OFF state may be analogous to a quarterback taking his mouthpiece out between plays.

Referring now to FIGS. 10-17, there is depicted a second embodiment of a breathing system. The breathing system includes a bridge member 122 and a pair of nasal appliques 24. The primary distinction between the first and second embodiments is the inclusion of a spacer 125 on the bridge member 122 for spacing the magnets 142 farther from the nasal appliques 24 to enhance the dilating force (e.g., the nasal appliques 24 are pulled farther). In this respect, the nasal appliques 24 used in the second embodiment are similar to the nasal appliques 24 discussed above in connection with the first embodiment. Thus, the following discussion will focus on the unique configuration of the bridge member 122.

The bridge member 122 includes an arcuate main body 126 having a concave inner surface 128 and an opposing convex outer surface 130. The main body 126 includes a middle portion 132 defining an apex which is located between two distal portions 134, wherein each distal portion 134 termi-

nates at a respective distal tip **136**. The two distal tips **136** are spaced from each other by a distance, D_2 which allows the bridge member **122** to fit over the user's nose **10**, with the distal portions **134** being positioned adjacent opposing lateral regions **18** of the user's nose **10**. The bridge member **122** may be fabricated in various sizes to accommodate differently sized noses, as well as to create different amounts of dilation. Along these lines, the distance D_2 may be anywhere from 1.0 inch for use on a small nose (e.g., for a child), to over 2.5 for use on a larger nose. For an average nose, the distance D_2 may be approximately equal to 1.75 inches.

The main body **122** includes a pair of opposed longitudinal edges **138** and a pair of opposed transverse edges **140**, which essentially define the aforementioned distal tips **136**. The distance between the opposed longitudinal edges **140** defines a bridge member thickness, T_2 , which may be equal to approximately 0.5 inches, although other thickness dimensions may be used without departing from the spirit and scope of the present invention.

The main body **126** is rigidly formed so as to substantially maintain its shape. Along these lines, the main body **126** is preferably more resistant to bending, or flexing than is the skin of the user's nose **10**. In this respect, the main body **126** is capable of being disposable in compression, that is to say, the main body **126** is capable of having a force applied thereto.

The bridge member **122** further includes a plurality of magnets **142** coupled to the concave inner surface **128** adjacent the distal portions **134** thereof. In the exemplary embodiment, the bridge member **122** includes a pair of magnets **142** at each distal portion **134**. The magnets **142** may be received within a cavity or recess formed within the main body **126** that is substantially complimentary in shape and size to the pair of magnets **142**. The magnets **142** may be adhered or otherwise coupled to the main body **126** using fastening mechanisms known by those skilled in the art.

Additionally coupled to the main body **126** at respective distal portions thereof is a pair of spacers **125**. Each spacer **125** is located adjacent a respective distal portion **134** of the main body **126** and includes a contact surface **127** and an opposing outer surface **129**, wherein the contact surface **127** is adapted to engage with the wearer's nose **10**. When viewed from the perspective shown in FIG. **17**, which is a cross-sectional view of the breathing system in use on a user's nose **10**, shown in phantom, the inner surface **128** of the main body **126** resides between the contact surface **127** of the spacer **125** and the outer surface **130** of the main body **126**. In this respect, the contact surface **127** is offset from the inner surface **128**.

Each spacer **125** additionally protrudes from the main body **126** beyond one of the longitudinal edges **138** and terminates at a tip **131**. In the exemplary embodiment, the spacer **125** defines an arcuate peripheral contour, although it is understood that in other embodiments, the peripheral contour of the spacer **125** may assume any shape or configuration.

During use of the breathing system, the nasal appliques **24** are applied to the user's nose **10**, as described above. Once the appliques **24** are applied, the user places the bridge member **122** over the nose **10**, with the contact surface **127** of the spacers **125** contacting respective lateral regions **18** of the user's nose **10**. As the bridge member **122** is moved closer to the nasal appliques **24**, the magnetic attraction between the magnets **142** and the metallic elements **44** pulls the appliques **24** outwardly, thereby imparting a dilating force on the lateral regions **18** of the nose **10**, causing the nose **10** to dilate. The

presence of the spacer **125** allows the metallic elements **44** to be drawn further to engage with the magnets **142**, which enhances the dilating effect.

The bridge member **122** may be disengaged from the nasal appliques **24** by pulling the bridge member **122** away from the appliques **24**. Once disengaged, the dilating force is no longer applied to the user's nose **10**, thereby allowing the nose **10** to retract and assume its normal position. In this respect, the breathing system may be selective transitioned between an ON state and an OFF state, as described above.

Referring now to FIGS. **18-33**, there is depicted several embodiments of bridge members adapted for use with the nasal appliques **24** described above. The bridge members shown in FIGS. **18-33** differ from the bridge members **22**, **122** previously shown and described by virtue of the ability of the bridge members shown in FIGS. **18-33** to flex and conform to the anatomy of the user's nose **10**. In some instances, the bridge members are flexible and capable of assuming a specific position (see FIGS. **18-25**), while other bridge members are flexible between a neutral position and a flexed position, with the bridge members being biased toward the neutral position.

Referring now specifically to FIGS. **18-21**, there is depicted a third embodiment of a bridge member **222** which includes a flexible middle portion **232** disposed between a distal members **234**. In the exemplary embodiment, the flexible middle portion **232** is comprised of a plurality of flexible bars **250**, specifically three bars **250**, although the number of bars **250** may vary without departing from the spirit and scope of the present invention. The bars **250** are flexible, and yet are of sufficient rigidity to independently maintain a desired configuration, similar to the ability of a conventional paperclip to be bent and assume a particular configuration, although the bars **250** are preferably of a more rigid stiffness than a conventional paperclip.

Each bar **250** is coupled to each distal member **234** at a respective end portion of the bar. Each distal member **234** includes a main body **252** having an inner surface **254**, an opposing outer surface **256**, and a set of engagement sleeves **258** coupled to the outer surface **256**, wherein the number of engagement sleeves **258** equals the number of bars **250**. Thus, in the exemplary embodiment, each main body **252** includes three engagement sleeves **258**, wherein each engagement sleeve **258** is specifically adapted to receive one of the bars **250** at a respective end portion thereof. Each main body **252** also defines a distal edge **260**, which is spaced away from the bars **250** and extend generally perpendicular to the bars **250**. The distal edges define a bridge member length, L_1 , which may be equal to approximately 2.0-3.0 inches when the bars **250** are generally linear (e.g., when the bridge member **222** is in a generally flat configuration).

Each distal member **234** additionally includes one or more magnets **242** coupled to the main body **252**. In the exemplary embodiment, each distal member **234** includes two magnets **242** coupled thereto. The magnets **242** may be received within a recess formed within the main body **252**.

The bridge member **222** is configured to be selectively bent or flexed into a prescribed configuration which generally conforms to the anatomy of the user's nose **10**. When the bridge member **22** is bent, the bars **250** are bent about a bend axis **265**, such that the distal members **234** are moved toward each other and the bend axis **265**. FIG. **19** depicts a user's hand (in phantom), pressing the distal members **234** together to bend the bridge member **222** into the desired configuration. As noted above, the bars **250** are preferably configured such

11

that when the bars **250** are bent into the desired configuration, the bars **250** are capable of staying in that desired configuration.

In use, the bridge member **222** is bent or flexed into the prescribed configuration based on the particularly anatomy or configuration of the user's nose **10**. Along these lines, the bridge member **222** is bent until the main bodies **252** are spaced slightly farther than the distance between the lateral regions **18** of the user's nose **10**. The bridge member **222** will maintain the prescribed, bent configuration due to the mechanical properties of the bars **250**.

After the bridge member **222** is bent and the nasal appliques **24** are applied to the nose **10**, the bridge member **222** is placed over the user's nose **10**, which causes the magnets **242** in the bridge member **222** to interact with the metallic elements **44** in the nasal appliques **24**. The interaction imparts a dilating force on the user's nose **10**, which in turn opens the nasal passageways **14** to enhance the user's ability to breathe. When the bridge member **222** is placed on the nasal appliques **24**, the system is considered to be "active" and in an ON state, whereas when the bridge member **222** is removed from the nasal appliques **24**, the system is considered to be "inactive" and in an OFF state.

Referring now to FIGS. **22-25**, there is depicted a fourth embodiment of a bridge member **322**, which is similar to the bridge member **222** depicted in FIGS. **18-21**, although the bridge member **322** includes a pair of spacers **325** coupled to respective ones of the main bodies **352**. In particular, the bridge member **322** generally includes a plurality of bars **350**, a pair of distal members **334**, wherein each distal member **334** includes a main body **352** and a plurality of sleeves **358** which engage with the bars **350**, similar to the sleeves described above.

Each spacer **325** is coupled to a respective one of the pair of main bodies **352** and includes a contact surface **327** and an opposing outer surface **329**, wherein the contact surface **327** is adapted to engage with the wearer's nose **10**. An inner surface **328** of the main body **352** resides between the contact surface **327** of the spacer **325** and an outer surface **330** of the main body **352**. In this respect, the contact surface **327** is offset from the inner surface **328**.

Each spacer **325** additionally protrudes from the main body **352** beyond one of the longitudinal edges and terminates at a tip **331**. In the exemplary embodiment, the spacer **325** defines an arcuate peripheral contour, although it is understood that in other embodiments, the peripheral contour of the spacer **325** may assume any shape or configuration.

The use of the bridge member **322** is similar to the use of the bridge member described above in relation to FIGS. **18-21**. However, the presence of the spacers **325** allows the metallic elements **44** to be drawn further to engage with the magnets **342**, which enhances the dilating effect.

Referring now to FIGS. **26-29**, there is depicted a fifth embodiment of a bridge member **422**, which is distinguishable from the bridge members discussed above primarily because of a flexible band **450** which allows the bridge member **422** to flex between a neutral position and a flexed position.

The bridge member **422** includes a flexible middle portion comprised of the flexible band **450**. The flexible band **450** is transitional between a neutral position, shown in FIGS. **26, 28** and **29**, and a flexed position, shown in FIG. **26** (in phantom) and FIG. **27**. The flexible band **450** differs from the flexible bars discussed above because the flexible band **450** is not capable of independently maintaining the flexed position. Rather, the flexible band **450** is biased toward the neutral

12

position, such that when the band **450** is not acted upon by an outside force, the band **450** returns to the neutral position.

The band **450** is coupled to a pair of distal members **434** at a respective end portions of the band **450**. Each distal member **434** includes an inner surface **428**, an opposing outer surface **430**, and an engagement pocket adapted to receive an end portion of the band **450**. In the exemplary embodiment, the engagement pocket extends from a medial end of the distal member **434**. The inner surface **428** may also include a cutout in communication with the pocket, wherein the cutout is sized to accommodate one or more magnets **442**, as described below. Each distal member **434** also defines a distal edge **460**, with the pair of distal edges **460** defining a bridge member length L_2 therebetween, which may be equal to approximately 2.0-3.0 inches when the band **450** is generally linear (e.g., when the bridge member **422** is in a generally flat configuration). The band **450** may optionally be coated in a soft, flexible material, such as rubber or fabric, to make the bridge member **422** more comfortable to wear.

Each bridge member **422** additionally includes one or more magnets **442** coupled to the distal members **434** and/or the band **450**. In the exemplary embodiment, each end portion of the band **450** includes two magnets **442** coupled thereto. As noted above, the magnets **442** are received within a cutout formed in the distal member **434**, such that the distal member **434** partially surrounds the magnets **442**.

In use, the nasal appliques **224** are applied to the lateral regions **18** of the user's nose **10** and the bridge member **422** is placed over the nasal appliques **24**. In particular, the band **450** is bent or flexed to generally conform to the anatomy of the user's nose **10**. When the band **450** is bent, the band **450** bends about a bend axis **465**, such that the distal members **434** are moved toward each other and the bend axis **465**. FIG. **27** depicts a user's hand (in phantom), pressing the distal members **434** together to bend the bridge member **422**. As the bridge member **422** is moved closer to the nasal appliques **24**, the magnets **442** in the bridge member **422** interact with the metallic elements **44** in the nasal appliques **24**. The magnetic attraction accomplishes two purposes: the first purpose is that the nasal appliques **24** are drawn toward the magnets **442**, which imparts a dilating force on the nose **10** causing the nasal passageways **14** to open; the second purpose is that the magnetic attraction maintains the bridge member **422** in the flexed configuration. As noted above, the bridge member **422** is biased toward the neutral position. Optionally, the biasing force may be strong enough to further dilate the user's nose **10**.

The bridge member **422** is configured to selectively transition the breathing system between ON (e.g., active) and OFF (e.g., inactive) states by simply engaging or disengaging the bridge member **422** with the nasal appliques **24**, similar to the bridge members discussed above.

Referring now to FIGS. **30-33**, there is depicted a sixth embodiment of a bridge member **522**, which is similar to the bridge member **422** discussed above, although the bridge member **522** includes a pair of spacers **525** coupled to respective ones of the distal members **534**. In particular, the bridge member **522** generally includes a flexible band **550**, a pair of distal members **534**, wherein each distal member **534** includes a pocket configured to engage with the band **550**.

Each spacer **525** is coupled to a respective one of the pair of distal members **534** and includes a contact surface **527** and an opposing outer surface **529**, wherein the contact surface **527** is adapted to engage with the wearer's nose **10**. The inner surface **528** of the distal member **534** resides between the contact surface **527** of the spacer **525** and the outer surface

530 of the distal member 534. In this respect, the contact surface 527 is offset from the inner surface 528.

Each spacer 525 additionally protrudes from the distal member 534 beyond one of the longitudinal edges and terminates at a tip 531. In the exemplary embodiment, the spacer 525 defines an arcuate peripheral contour, although it is understood that in other embodiments, the peripheral contour of the spacer 525 may assume any shape or configuration.

The use of the bridge member 522 is similar to the use of the bridge member 422 described above in relation to FIGS. 26-29. However, the presence of the spacers 525 allows the metallic elements 44 to be drawn out further to engage with the magnets 542, which enhances the dilating effect.

Referring now to FIGS. 34-36, there is depicted a seventh embodiment of a bridge member 622 that is specifically configured and adapted to not only interface with nasal appliques 24, but is also adapted to interface with a lens 660, such as a glasses lens, goggle lens, or other optical lens. The interaction between the bridge member 622 and the lens 660 may be sufficient to stabilize the lens on the user's nose to allow the lens 660 to reside over the wearer's eyes without the use of a support strap or arms, as are commonly employed with goggles and glasses frames, respectively. In particular, the lens 660 includes a peripheral edge defining a bridge section 662 and a pair of lower sections 664, with each lower section 664 transitioning to a respective side section 668. The bridge section 662 may include a pair of tabs 670 for engaging with the bridge member, as will be described in more detail below.

The bridge member 622 includes a main body 626 having a concave inner surface 628 and a convex outer surface 630. The bridge member 622 defines a middle portion 632 and a pair of distal portions 634. Attached to each distal portion 634 is at least one magnet 642. The magnet 642 may reside within a recess which extends into the main body 626 from the concave inner surface 630. The bridge member 622 may further include a lens receiving recess or opening 635 extending into the bridge member 622 from the convex outer surface 628. The lens receiving opening 635 may be adapted to receive respective ones of the tabs 670 for connecting the lens 660 to the bridge member 622.

The bridge member 622 may be selectively transitioned relative to the lens between a disengaged configuration (see FIG. 34) and an engaged configuration (see FIG. 35). The user may engage the bridge member 622 with the lens 660 by pressing the convex outer surface 630 against the bridge section 662 of the lens 660, until the bridge section 662 is received within the lens receiving opening 635 (as shown in FIG. 35).

The bridge member-lens assembly may be attached to the user's nose 10 via the nasal appliques 24. In particular, as the bridge member 622 is moved closer to the nasal appliques 24, the magnets 642 in the bridge member 622 interact with the metallic elements 44 in the nasal appliques 24, such that the magnetic force therebetween holds the lens 660 in place over the user's nose 10. Furthermore, the magnetic attraction also imparts a dilating force on the user's nose 10 causing the nasal passageways 14 to open for enhancing the user's ability to breathe.

While FIGS. 34-36 show bridge member 622 as being adapted to for use in stabilizing and securing the lens 660 in place on the user, it is understood that any one of the foregoing embodiments of the bridge member described above and shown in the Figures may be adapted for use with the lens 660.

Although the foregoing describes the nasal appliques 24 as including the metallic elements, and the magnets as being part of the bridge member, it is understood that in other embodi-

ments, the location of the magnets and metallic elements may be reversed. In particular, the metallic elements may be part of the bridge member and the magnets may be part of the nasal appliques. Alternatively, it is also understood that the metallic elements may be replaced with magnets, such that both the bridge members and nasal appliques have magnets which are polar opposites, and thereby are attracted to each other.

The particulars shown herein are by way of example only for purposes of illustrative discussion, and are not presented in the cause of providing what is believed to be most useful and readily understood description of the principles and conceptual aspects of the various embodiments of the present disclosure. In this regard, no attempt is made to show any more detail than is necessary for a fundamental understanding of the different features of the various embodiments, the description taken with the drawings making apparent to those skilled in the art how these may be implemented in practice.

What is claimed is:

1. A disposable nasal applique attachable to a nose of a wearer and configured for use with a magnet positioned adjacent to the nose of the wearer, the disposable nasal applique comprising:

a flexible base layer including a first surface and an opposing second surface, the first surface having an adhesive disposed thereon to enable the first surface to be selectively attachable to the nose of the wearer, the flexible base layer having a pair of end portions and a narrow portion disposed between the pair of end portions; and a metallic element coupled to the second surface of the base layer and being configured to interact with the magnet when the magnet is positioned adjacent the nose of the wearer and the flexible base layer is attached to the nose of the wearer, the interaction between the metallic element and the magnet imparting a dilating force on the nose of the wearer causing the nose of the wearer to dilate;

the metallic element being configured to allow for unrestricted movement of the magnet relative to the metallic element along at least two axes when the magnet is magnetically held adjacent to the metallic element;

the nasal applique, while being attached to the nose of the wearer, being selectively transitional between an active state and an inactive state, in the active state, the metallic element magnetically interacts with the magnet to impart the dilating force on the nose of the wearer, in the inactive state, the metallic element is magnetically decoupled from the magnet to cease imparting of the dilating force on the nose of the wearer.

2. The nasal applique recited in claim 1, wherein the narrow portion is defined by at least one concave peripheral segment.

3. The nasal applique recited in claim 1, wherein the narrow portion is defined by a pair of opposed concave peripheral segments.

4. The nasal applique recited in claim 1, wherein the metallic element is configured to impart the dilating force only in response to interaction between the metallic element and the magnet.

5. The nasal applique recited in claim 1, wherein the metallic element is of sufficient rigidity to retain its shape when the flexible attachment layer is attached to the nose.

6. The nasal applique recited in claim 1, further comprising an outer layer coupled to the base layer and extending over the metallic element to at least partially cover the metallic element.

7. The nasal applique recited in claim 1, wherein the metallic element is circular.

15

8. The nasal applique recited in claim 1, wherein one end portion of the base layer is larger than the other end portion of the base layer.

9. The nasal applique recited in claim 1, wherein the metallic element includes a convex outer surface.

10. The nasal applique recited in claim 1, wherein the nasal applique is adapted to impart a dilating force adjacent a single nostril on the nose of the wearer.

11. The nasal applique recited in claim 1, further comprising a cover layer, the metallic element being captured between the cover layer and the base layer.

12. The nasal applique recited in claim 1, wherein the metallic element is disposed about an axis and is of a maximum thickness at the axis.

13. The nasal applique recited in claim 1, wherein the metallic element is configured to disallow mechanical coupling between the metallic element and the magnet when the magnet is magnetically interacting with the metallic element.

14. The nasal applique recited in claim 13, wherein the metallic element is configured to be coupled to the magnet solely via magnetic interaction therebetween.

15. A nasal dilating system for use on a nose of a wearer, the nasal dilating system comprising:

a magnet;

a flexible base layer including a first surface and an opposing second surface, the first surface having an adhesive disposed thereon to enable the first surface to be selectively attachable to the nose of the wearer, the flexible base layer having a pair of end portions and a narrow portion disposed between the pair of end portions; and a metallic element coupled to the second surface of the base layer and being configured to interact with the magnet when the magnet is positioned adjacent the nose of the wearer and the flexible base layer is attached to the nose of the wearer, the interaction between the metallic element and the magnet imparting a dilating force on the nose of the wearer causing the nose of the wearer to dilate;

the metallic element being configured to allow for unrestricted movement of the magnet relative to the metallic element along at least two axes when the magnet is magnetically coupled thereto;

the nasal applique, while being attached to the nose of the wearer, being selectively transitional between an active state and an inactive state, in the active state, the metallic element magnetically interacts with the magnet to impart the dilating force on the nose of the wearer, in the

16

inactive state, the metallic element is magnetically decoupled from the magnet to cease imparting of the dilating force on the nose of the wearer.

16. The nasal dilating system recited in claim 15, wherein the narrow portion is defined by at least one concave peripheral segment.

17. The nasal dilating system recited in claim 15, wherein the narrow portion is defined by a pair of opposed concave peripheral segments.

18. The nasal dilating system recited in claim 15, wherein the metallic element is configured to impart the dilating force only in response to interaction between the metallic element and the magnet.

19. The nasal dilating system recited in claim 15, wherein the metallic element is of sufficient rigidity to retain its shape when the flexible attachment layer is attached to the nose.

20. The nasal dilating system recited in claim 15, further comprising an outer layer coupled to the base layer and extending over the metallic element to at least partially cover the metallic element.

21. The nasal dilating system recited in claim 15, wherein the metallic element is circular.

22. The nasal dilating system recited in claim 15, wherein one end portion of the base layer is larger than the other end portion of the base layer.

23. The nasal dilating system recited in claim 15, wherein the metallic element includes a convex outer surface.

24. The nasal dilating system recited in claim 15, wherein the nasal applique is adapted to impart a dilating force adjacent a single nostril on the nose of the wearer.

25. The nasal dilating system recited in claim 15, further comprising a cover layer, the metallic element being captured between the cover layer and the base layer.

26. The nasal dilating system recited in claim 15, wherein the metallic element is disposed about an axis and is of a maximum thickness at the axis.

27. The nasal dilating system recited in claim 15, wherein the metallic element and the magnet are configured to disallow mechanical coupling between the metallic element and the magnet when the magnet is magnetically interacting with the metallic element.

28. The nasal dilating system recited in claim 27, wherein the metallic element and the magnet are configured to be coupled to each other solely via magnetic interaction therebetween.

* * * * *